

Date: \_\_\_\_\_ ☐ Truck#: \_\_\_\_\_ Operator: \_\_\_\_\_

Start Hour: \_\_\_\_\_ ☐ End Hour: \_\_\_\_\_ ☐ Fuel: \_\_\_\_\_

# Electric Truck Daily Check List

Indicate an **X** where a problem is detected and a **✓** to indicate no problems visible.

## Visual Inspection

COMMENTS

1.  Battery \_\_\_\_\_
- Vent Caps \_\_\_\_\_
- Connector Covers \_\_\_\_\_
- Cables \_\_\_\_\_
2.  Overhead Guard \_\_\_\_\_
3.  Front Tire (Left) \_\_\_\_\_
4.  Tilt Cylinder \_\_\_\_\_
5.  Carriage \_\_\_\_\_
6.  Fork Locking Pin (Left) \_\_\_\_\_
7.  Fork (Left) \_\_\_\_\_
- (Attachment Applicable) \_\_\_\_\_
8.  Mast \_\_\_\_\_
9.  Lift Cylinder \_\_\_\_\_
- Lift Chains \_\_\_\_\_
10.  Fork (Right) \_\_\_\_\_
- (Attachment Applicable) \_\_\_\_\_
11.  Fork Locking Pin (Right) \_\_\_\_\_
12.  Carriage \_\_\_\_\_
13.  Tilt Cylinder \_\_\_\_\_
14.  Front Tire (Right) \_\_\_\_\_
15.  Hydraulic Oil \_\_\_\_\_
16.  Battery Connectors \_\_\_\_\_
17.  Seat & Seat Belt \_\_\_\_\_
18.  Overhead Guard \_\_\_\_\_
19.  Rear Tire (Right) \_\_\_\_\_
20.  Rear Tire (Left) \_\_\_\_\_

## Operational Inspection

COMMENTS

- A.  Listen for Unusual Noise \_\_\_\_\_
- B.  Check Service & Parking Brake \_\_\_\_\_
- C.  Lifting Control \_\_\_\_\_
- D.  Tilt Control \_\_\_\_\_
- E.  Forward Driving \_\_\_\_\_
  - Accelerator \_\_\_\_\_
  - Steering \_\_\_\_\_
  - Braking \_\_\_\_\_
- F.  Reverse Driving \_\_\_\_\_
  - Accelerator \_\_\_\_\_
  - Steering \_\_\_\_\_
  - Braking \_\_\_\_\_
  - Backup Alarm \_\_\_\_\_
- G.  Lights \_\_\_\_\_
- H.  Horn \_\_\_\_\_
- I.  Gauges \_\_\_\_\_
- J.  Oil Spots on Floor \_\_\_\_\_

## WALK AROUND

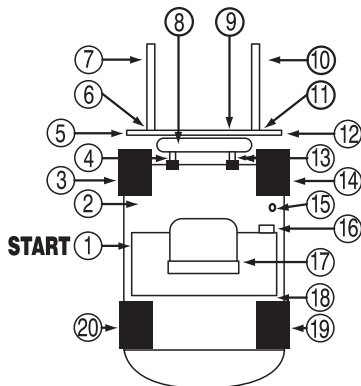

All comments made in reference to any problems should be made on the back of this page in detail and handed to the supervisor immediately.

**SIGNATURE:**

**CAUTION:** This is not a complete list of all items which may require attention. Operators are responsible for ensuring that the lift truck is in proper working condition in accordance with the manufacturer's specifications.

**DO NOT** operate lift truck if a problem is detected. Report all problems to the service department immediately.

**TO BE COMPLETED BY DESIGNATED OPERATOR AND FORWARDED TO SUPERVISOR PRIOR TO SHIFT.**