

Date: _____ Truck#: _____ Operator: _____

Start Hour: _____ End Hour: _____ Fuel: _____

INTERNAL COMBUSTION DAILY CHECK LIST

Indicate an **X** where a problem is detected and a **✓** to indicate no problems visible.

Visual Inspection

COMMENTS

1. Propane
 - Relief Valve _____
 - Fuel Level _____
 - No Leaks _____
 - Safety Straps _____
2. Rear Tire (Left) _____
3. Engine Compartment
 - Oil _____
 - Radiator _____
 - Air Filter _____
 - Fan Belt _____
4. Overhead Guard _____
5. Front Tire (Left) _____
6. Tilt Cylinder _____
7. Carriage _____
8. Fork Locking Pin (Left) _____
9. Fork (Left) _____
 - (Attachment Applicable) _____
10. Mast _____
11. Lift Cylinder
 - Lift Chains _____
12. Fork (Right) _____
 - (Attachment Applicable) _____
13. Fork Locking Pin (Right) _____
14. Carriage _____
15. Tilt Cylinder _____
16. Front Tire (Right) _____
17. Hydraulic Oil _____
18. Battery _____
19. Seat & Seat Belt _____
20. Overhead Guard _____
21. Rear Tire (Right) _____

Operational Inspection

COMMENTS

- A. Listen for Unusual Noise _____
- B. Check Service & Parking Brake _____
- C. Lifting Control _____
- D. Tilt Control _____
- E. Forward Driving
 - Accelerator _____
 - Steering _____
 - Braking _____
- F. Reverse Driving
 - Accelerators _____
 - Steering _____
 - Braking _____
 - Backup Alarm _____
- G. Lights _____
- H. Horn _____
- I. Gauges _____
- J. Oil Spots on Floor _____

WALK AROUND

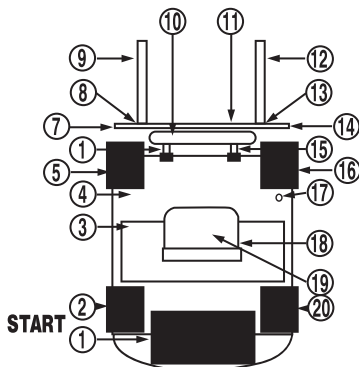

All comments made in reference to any problems should be made on the back of this page in detail and handed to the supervisor immediately.

SIGNATURE:

CAUTION: This is not a complete list of all items which may require attention. Operators are responsible for ensuring that the lift truck is in proper working condition in accordance with the manufacturer's specifications.

DO NOT operate lift truck if a problem is detected. Report all problems to the service department immediately.

TO BE COMPLETED BY DESIGNATED OPERATOR AND FORWARDED TO SUPERVISOR PRIOR TO SHIFT.