

Date: _____ Truck#: _____ Operator: _____

Start Hour: _____ End Hour: _____ Fuel: _____

Narrow Aisle Lift Truck Check List

Indicate an **X** where a problem is detected and a **✓** to indicate no problems visible.

Visual Inspection

COMMENTS

1. Battery _____
 - Vent Caps _____
 - Connector Covers _____
 - Cables _____
2. Drive and Load Wheel _____
3. Overhead Guard _____
4. Tilt Cylinder _____
5. Carriage _____
6. Forks _____
7. Mast _____
8. Cylinder Lift _____
 - (Tilt and Reach if Applicable) _____
9. Lift Chains _____
10. Nameplate _____
11. Battery Retainer Plate _____
 - (Attachment if Applicable) _____

Order Picker WALK AROUND

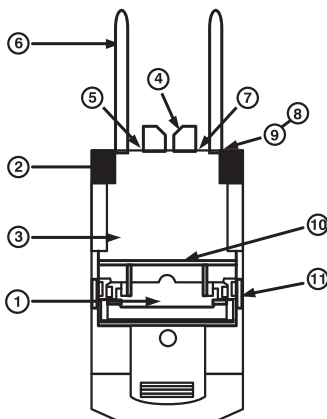

Operational Inspection

COMMENTS

- A. Listen for Unusual Noise _____
- B. Parking Brake _____
- C. Lifting Control _____
- D. Tilt Control _____
- E. Forward Driving _____
 - Steering _____
 - Braking _____
- F. Reverse Driving _____
 - Steering _____
 - Braking _____
 - Backup Alarm (Optional) _____
- G. Lights _____
- H. Horn _____
- I. Gauges _____
- J. Oil Spots on Floor _____

Reach Truck WALK AROUND

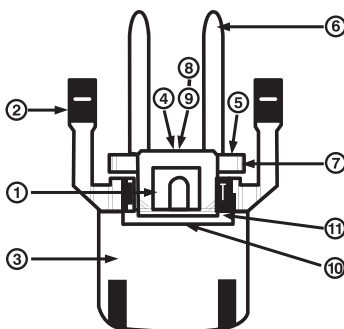

All comments made in reference to any problems should be made on the back of this page in detail and handed to the supervisor immediately.

SIGNATURE:

CAUTION: This is not a complete list of all items which may require attention. Operators are responsible for ensuring that the lift truck is in proper working condition in accordance with the manufacturer's specifications.

DO NOT operate lift truck if a problem is detected. Report all problems to the service department immediately.

TO BE COMPLETED BY DESIGNATED OPERATOR AND FORWARDED TO SUPERVISOR PRIOR TO SHIFT.